

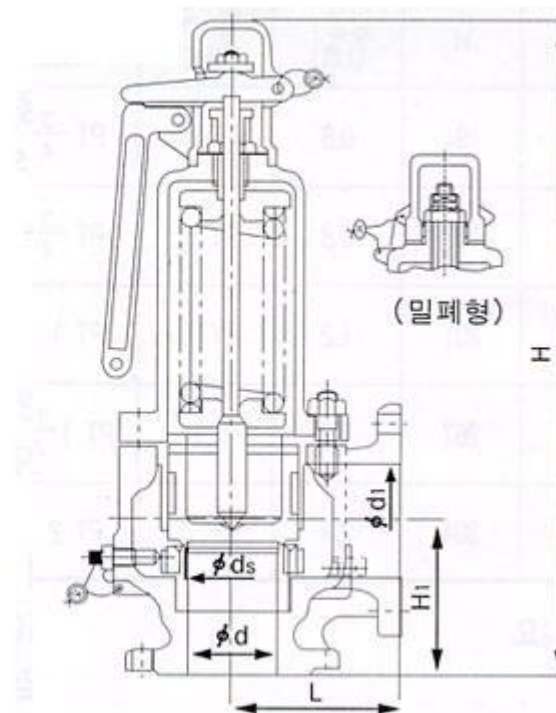

**Mode : [JSV-HF11] Safety Valve with High Lift Type**

**Size:** 20A~100A

**Used :** This is generally used for medium-size steam boiler, various pressure vessels and tracing equipment as safety valve and relief valve in pump.



- FEATURES**
1. This product is designed and produced by spring safety valve for steam and gas (KS B 6276).
  2. Lever type could execute the discharge inspection manually at over 75% of discharge pressure.
  3. Its sealing structure does not allow controlling pressure optionally.
  4. This product is approved by Korea Occupation Safety & Health Agency. **Dimensions (Unit: mm)**

Size	d	d1	dS	L	H1	H	Lift	Inlet	Outlet
------	---	----	----	---	----	---	------	-------	--------

20A-25A	20	25	21	80	75	280	1.5	KS 10K RF Flanged (KS B 6216)	KS 10K FF Flanged (KS B 1511)
25A-40A	25	40	26	90	85	320	2.0		
32A-40A	32	40	33	102	90	330	2.2		
40A-50A	40	50	41	115	100	385	3.0		
50A-65A	50	65	51	122	112	440	4.0		
65A-80A	65	80	66	140	125	520	5.0		
80A-100A	80	100	81	165	145	595	6.0		
100A-125A	100	125	101	175	167	690	7.0		

**SPECIFICATIONS**

TYPE	Applicable FLUID	Applicable Pressure (kgf/cm <sup>2</sup> )	Max. Operating Temp	MATERIAL		CONNECTION	HYDRAULIC PRESSURE TEST
				Body and TRIM	BONNET		
LEVER TYPE	AIR, GAS	0.35~1.0 {0.035~0.1} 1.0~11.0 {0.1~1.1}	220	CAST IRON	STAINLESS STEEL	INLET : KS 10K RF Flanged (KS B 6216)	22kgf/cm <sup>2</sup> {2.2MPa}
PACKED TYPE	LIQUIDS, WATER (HOT WATER)					OUTLET : KS 10K FF Flanged (KS B 1511)	

**BTK CO.,LTD**

Trụ sở chính: P304- CT6 CHUNG CƯ YÊN HÒA-P.YÊN HÒA-Q. CẦU GIẤY - HÀ NỘI  
 VPGD: 58 B Vũ Trọng Phụng - Thanh Xuân - Hà Nội  
 Điện thoại: 043.5579 303 Fax: 043.5577 015  
 Email: sales@btk.vn Website: btk-online.vn