

## UM-8 Series

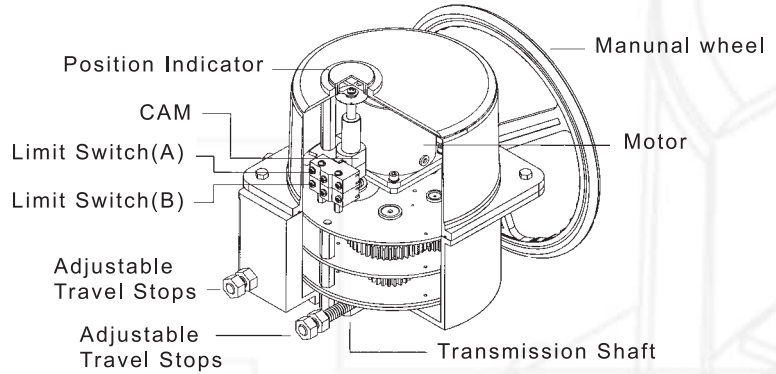

Weight : 32 kg



Specification	Speed(sec)		Output Troque Kgf-cm				
	110VAC	220VAC	AC	DC	110VAC	220VAC	24VDC
Power	110VAC	220VAC	AC	DC	110VAC	220VAC	24VDC
100W	0.92A	0.34A	37	N/A	11038	9296	N/A

The Size Of Valve		
Flanged Ends	Butterfly Valve	3-Way Valve
6" ~ 8"	12" ~ 14"	5" ~ 6"

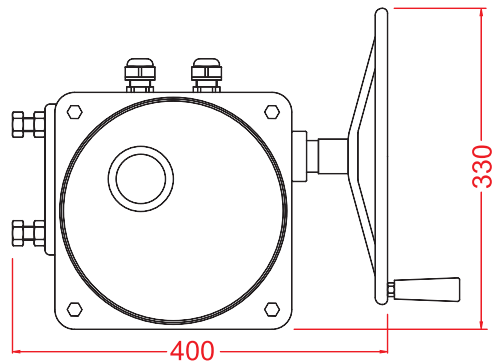

(mm)

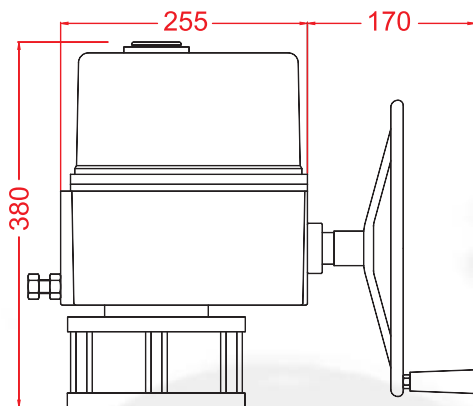

Mounting pattern is depending on valve

